

# FUTEK MODEL TAT500

# TORQUE WRENCH

(Previously T6000)

Drawing Number: FI1149

INCH [mm] | R.O.= Rated Output

### WIRING CODE (WC4)

+Excitation	-Excitation	+Signal	-Signal
RED	BLACK	GREEN	WHITE
+Sense	-Sense	Shield	
ORANGE	BLUE	Grounded	

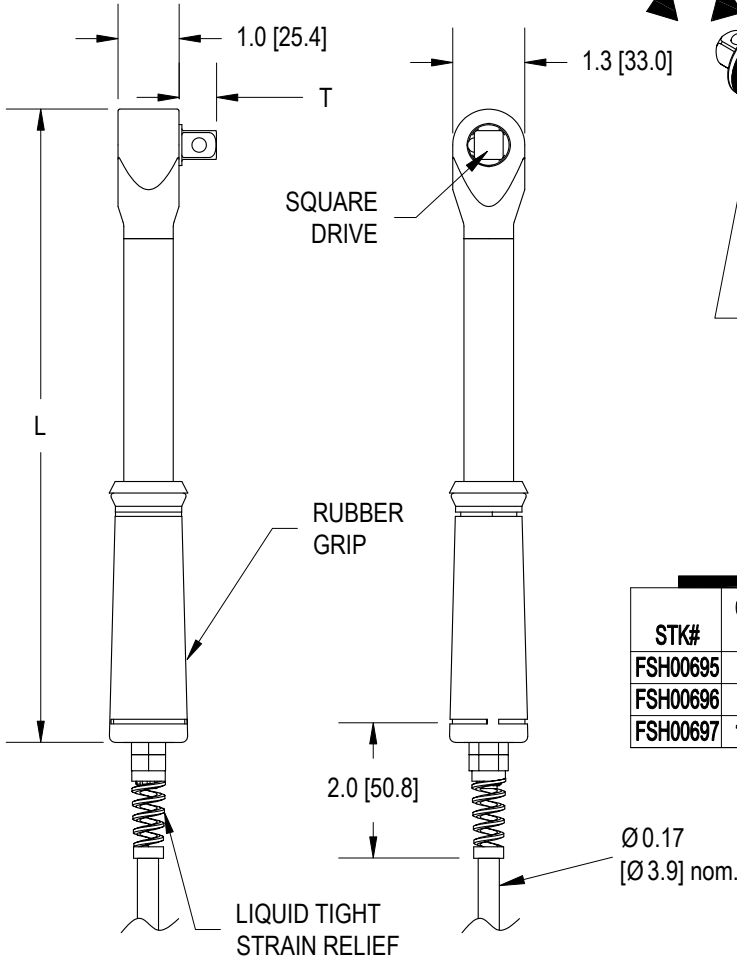
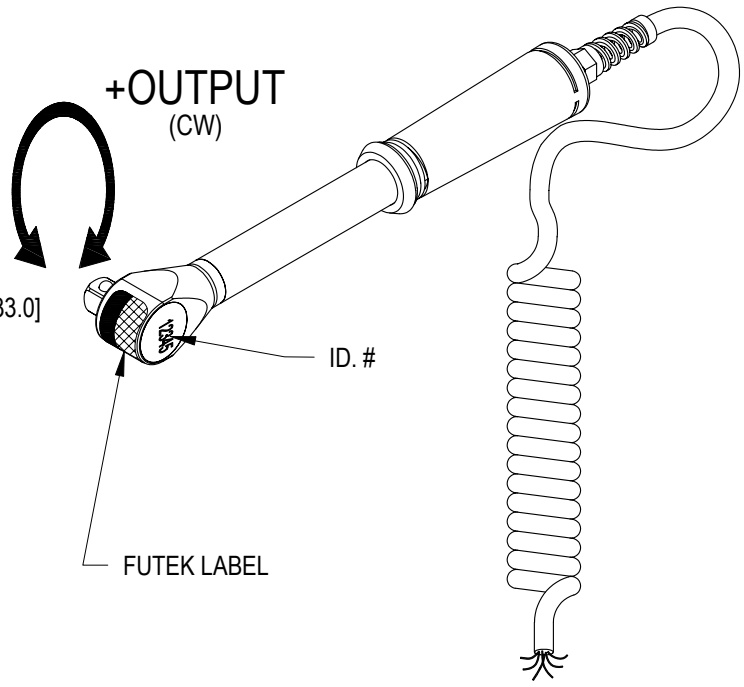

STK#	CAPACITY		L	T	SQUARE DRIVE	TORSIONAL STIFFNESS	WEIGHT
	in-lb	N m				in-lb/rad	
FSH00695	120	15	11 [280]	0.5 [12.7]	3/8"	22000	30 oz [0.9 Kg]
FSH00696	600	60	14 [355]			1.92 X 10 <sup>5</sup>	35 oz [1.0 Kg]
FSH00697	1200	150	20 [508]	0.7 [17.8]	1/2"	4.88 X 10 <sup>5</sup>	45 oz [1.3 Kg]

### SPECIFICATIONS:

<b>RATED OUTPUT</b>	2 mV/V nom.
<b>SAFE OVERLOAD</b>	150% of R.O.
<b>ZERO BALANCE</b>	±2% of R.O.
<b>EXCITATION (VDC OR VAC)</b>	18 MAX
<b>BRIDGE RESISTANCE</b>	350 Ω nom.
<b>NONLINEARITY</b>	±0.25% of R.O.
<b>HYSTERESIS</b>	±0.25% of R.O.
<b>NONREPEATABILITY</b>	±0.1% of R.O.
<b>TEMP. SHIFT ZERO</b>	±0.01% of R.O./°F [0.018% of R.O./°C]
<b>TEMP. SHIFT SPAN</b>	±0.02% of LOAD/°F [0.036% of LOAD/°C]
<b>COMPENSATED TEMP.</b>	60 to 160°F [15 to 72°C]
<b>OPERATING TEMP.</b>	-40 to 180°F [-40 to 82°C]
<b>MATERIAL (FLEXURE)</b>	17-4PH S.S.
<b>MATERIAL (HOUSING)</b>	STAINLESS STEEL
<b>CABLE: #28 AWG, 6 Conductor, Retractable PVC Cable 10 ft [3 m] Long Extended</b>	
<b>ACCESSORIES AND RELATED INSTRUMENTS AVAILABLE</b>	
<b>CALIBRATION (STD)</b>	5 pt. CW; 60.4KΩ SHUNT CAL. VALUE
<b>CALIBRATION TEST EXCITATION</b>	10 VDC

### AMPLIFIED VERSION

WIRING CODE		
12.5-24 VDC	GROUND	SIGNAL (0-5 VDC)
RED	BLACK	GREEN

**SPECIFICATIONS:**

<b>RATED OUTPUT</b>	0-5 VDC
<b>POWER REQUIRED</b>	12.5-24 VDC