



FEATURES

- 21k point data logging
- Bridge resistance measurement
- Keypad options (Track/Hold - Peak/Valley Reset - Unit - Tare/Gross-Shunt - Channel - Display-Menu)
- First peak/first valley feature
- User friendly navigation menu
- Shunt calibration
- Universal unit conversion
- 14 Sensor profile storage
- Supports 1451.4 standard (TEDS template 30 and 33)
- Powers on when plugged in (QSH01633 Version)

IMPORTANT NOTE: ONLY CONNECT DEVICE TO USB 2.0 PORT

SPECIFICATIONS

GENERAL

Data Logging	21k points
Profile Storage	14 profiles
Sampling Rate	5-4800 SPS
Internal Resolution	24 bits
Resolution (Noise Free)	See Chart on Page 2
Integrated Digital Filter	50 Hz/60 Hz Rejection (120 dB)
Operating Temperature	-4 to 158°F (-20 to 70°C)
Storage Temperature	-22 to 176°F (-30 to 80°C)
Weight	1.9 lb (862 g)
Internal Shunt Resistance Value	150 kOhm
Readout Nonlinearity	± 0.005% of FSR
Front Panel IP Rating	IP50

STRAIN GAUGE mV/V INPUT

Bridge Excitation	Precision 5.000 VDC
Standard Input Range	± 2 mV/V (factory default)
Optional Input Range	Up to ± 500 mV/V
Min. Bridge Resistance	30 Ohm
Reading Error**	± 0.15% of 2 mV/V

VOLTAGE INPUT

Standard Input Range	±12 VDC
Reading Error**	± 0.06% of 10 VDC

CURRENT INPUT

Standard Input Range	0-30 mA
----------------------	---------

OUTPUT

Analog Voltage	0-5 or ±5 VDC*
Minimum Load Impedance (Voltage)	10 kOhm
Analog Current	0-20, 4-20, 0-25, 5-25 mA*
Maximum Load Impedance (Current)	40 Ohm
2 Individual Relay Outputs	110 V/100 mA max, 1 mS response time
External Supply Output	24 VDC @ 100 mA max
USB	Digital Packetized Data
ASCII Output Update Rate	5 SPS

POWER ADAPTER

Input	90-264 VAC
Frequency	47-63 Hz
Input Current	0.35 A rms @ 120 VAC; 0.25 A @ 240 VAC
Output	15 VDC @ 1.2 A

CONFORMITY

RoHS	EU 2015/863
CE	EN55011; EN61326-1

* Refer to IHH500 User Manual for conditions on analog output bandwidth.

** When no system calibration is performed.

DIMENSIONS inches [mm]

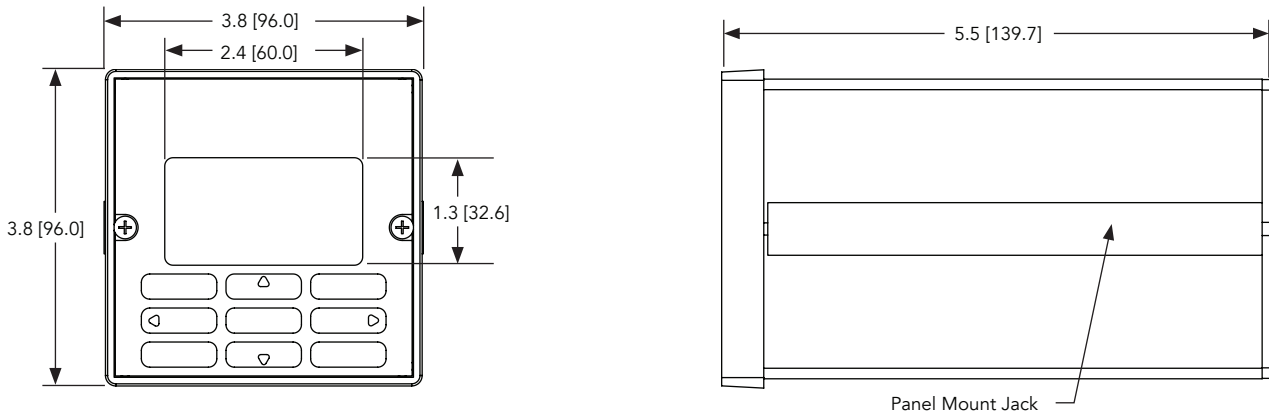

RECOMMENDED PANEL CUTOUT inches [mm]

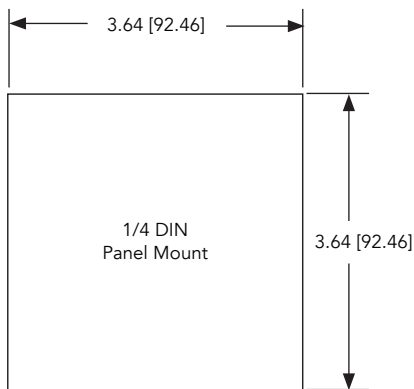

PANEL MOUNT JACK inches [mm]

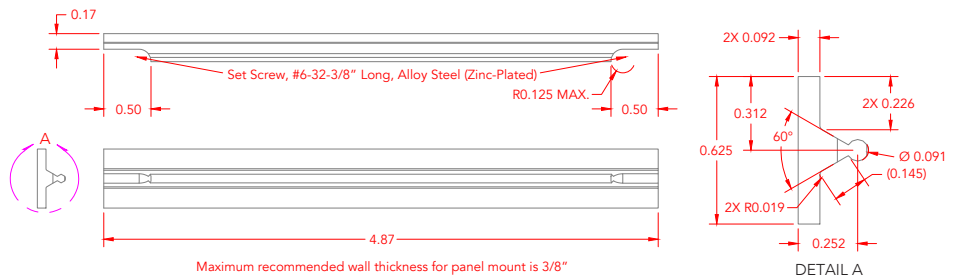

CONNECTORS

- 1 Input Power: 15 VDC ± 0.75 @ 1.2 A
- 2 Strain Gauge Input
- 3 USB Type B Socket
- 4 Amplified Input
- 5 Relays
- 6 Analog Output

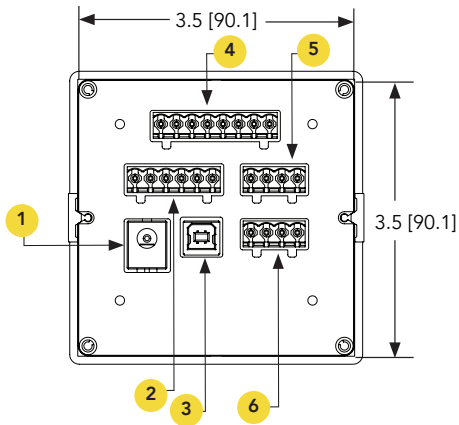

SAMPLING RATE

SAMPLES PER SECOND (SPS)	mV/V RESOLUTION	mA AND VDC INPUT RESOLUTION
5	18.7	21.4
50	17.3	17.3
100	16.8	18.6
600	15.1	17.2
1200	14.7	16.8
2400	14.3	16.3
4800	13.8	15.3

CONNECTORS & WIRING DIAGRAM

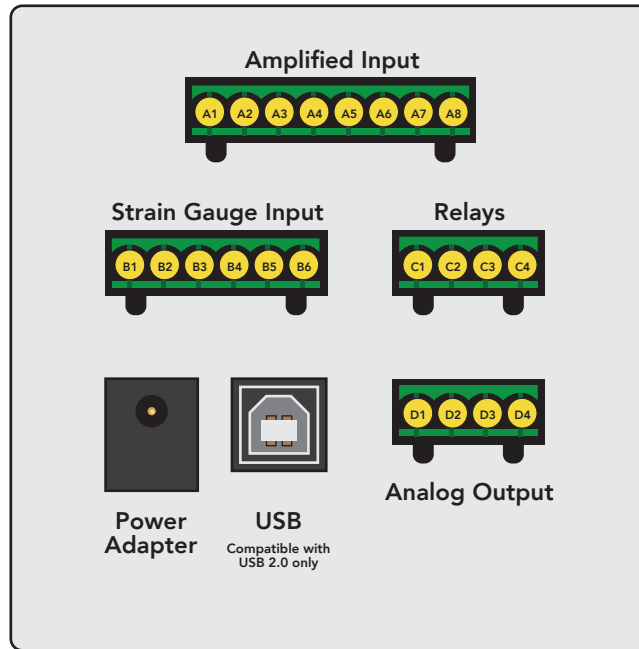

AMPLIFIED INPUT

PIN	SYMBOL	DESCRIPTION
A1	G	Ground/Shield
A2	G	Ground/Shield
A3	24V OUT	24VDC Output
A4	5V OUT	5VDC Output
A5	-V	-V and -mA Amplified Input Connections
A6	+V	+V and +mA Amplified Input Connections
A7	PLEAD	n/a
A8	PLAG	n/a

STRAIN GAUGE INPUT

PIN	SYMBOL	DESCRIPTION
B1	G	Ground/Shield
B2	TEDS	TEDS Data
B3	-S	-Signal
B4	+S	+Signal
B5	-E	-Excitation
B6	+E	+Excitation

RELAYS

PIN	SYMBOL	DESCRIPTION
C1	-R2	Solid State Relay 2 (-)
C2	+R2	Solid State Relay 2 (+)
C3	-R1	Solid State Relay 1 (-)
C4	+R1	Solid State Relay 1 (+)

ANALOG OUTPUT

PIN	SYMBOL	DESCRIPTION
D1	-VOUT	Voltage Output (-)
D2	+VOUT	Voltage Output (+)
D3	G	Ground (current)
D4	IOUT	Current Output

Note: Shield should only be connected on either sensor side or instrument side. If connected on instrument side use following directions. Connect shield to pin A1 or pin A2 of Amplified Input if sensor is amplified. Connect shield to pin B1 of Strain Gauge Input if sensor is strain gauge.

Drawing Number: F11340-O

FUTEK reserves the right to modify its design and specifications without notice. Please visit <http://www.futek.com/salesterms> for complete terms and conditions.

10 Thomas, Irvine, CA 92618 USA

Tel: (949) 465-0900
Fax: (949) 465-0905

www.futek.com



RoHS



U.S. Manufacturer