

FUTEK MODEL QLA122
STOCK NUMBER: QSH01039

LOW PROFILE UNIVERSAL PANCAKE LOAD CELL W/ INTERNAL STRAIN RELIEF
Previously L2900-Q11307

INCH [mm]		R.O.= Rated Output	
WIRING CODE (WC4)			
+Excitation	-Excitation	+Signal	-Signal
RED	BLACK	GREEN	WHITE
+Sense	-Sense	Shield	
ORANGE	BLUE	FLOATING	

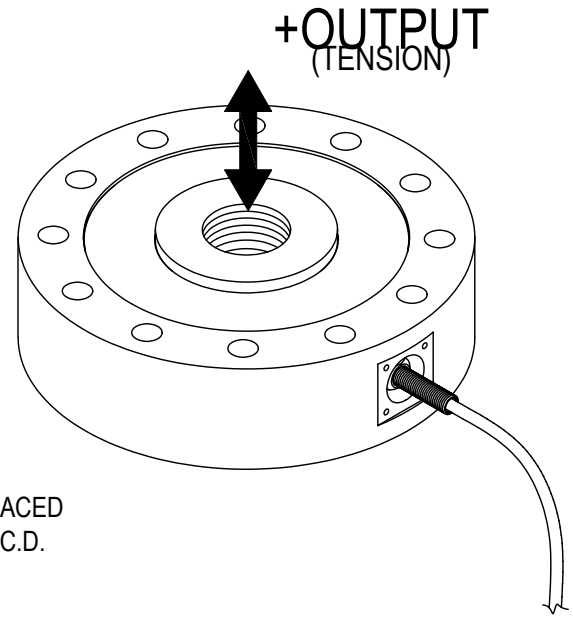
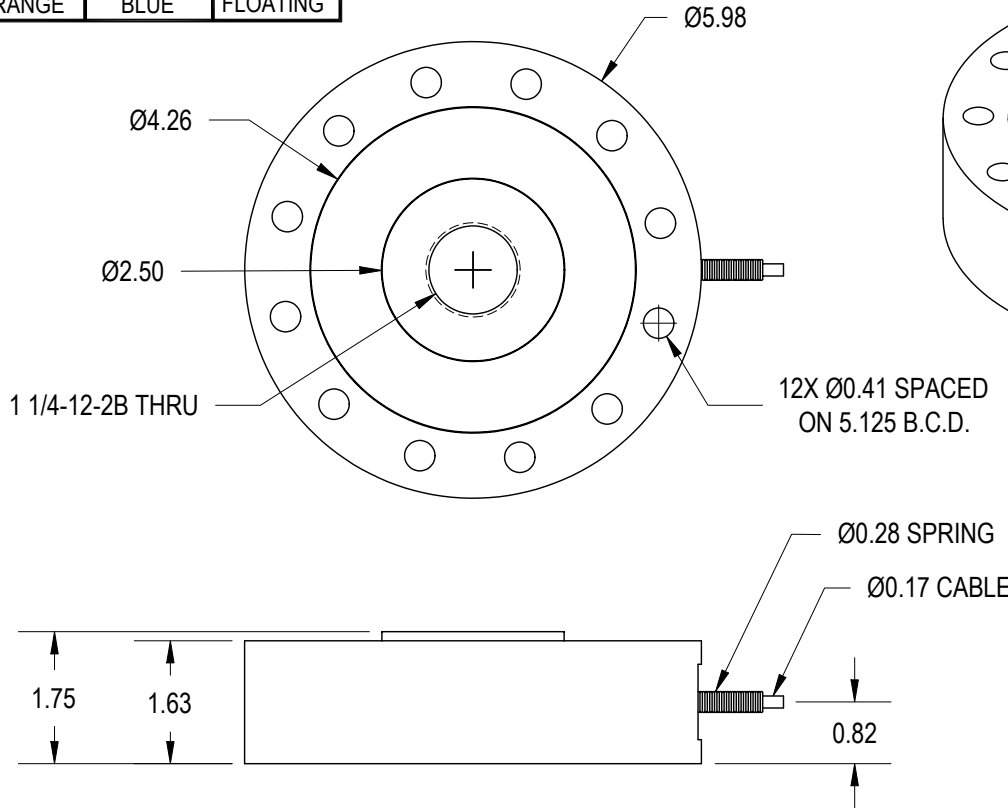

SPECIFICATIONS:

RATED OUTPUT	4 mV/V nom
CAPACITY	50000 lb
SAFE OVERLOAD	150% of R.O.
ZERO BALANCE	±1% of R.O.
EXCITATION (VDC OR VAC)	20 MAX.
BRIDGE RESISTANCE	350Ω nom.
NONLINEARITY	±0.12% of R.O.
HYSTERESIS	±0.12% of R.O.
NONREPEATABILITY	±0.02% of R.O.
TEMP. SHIFT ZERO	±0.001% of R.O./°F (0.0018% of R.O./°C)
TEMP. SHIFT SPAN	±0.002% of LOAD/°F (0.0036% of LOAD/°C)
COMPENSATED TEMP.	60 to 160°F (15 to 72°C)
OPERATING TEMP.	-60 to 200°F (-50 to 93°C)
DEFLECTION	0.002 nom
MATERIAL	STAINLESS STEEL
CABLE: 28 Awg, 6 Conductor Spiral Shielded Polyurethane Cable, 5 ft Long	

Previously Dwg# F4173 Rev. B

MATERIAL:	—
HEAT TREATMENT - FINISH:	—
REVISIONS: (Refer to dwg # revision sheet)	
△ 12-19-07	

OUTLINE DRAWING

STANDARD NOTES: (Unless Otherwise Specified)

- ALL DIMENSIONS ARE IN INCHES
- DRAWING INTERPRETATION DIMS. PER ASME-Y14.5M
- REMOVE BURRS AND BREAK SHARP EDGES .005 - .015
- THREADS PER HANDBOOK H-28
- DIMENSIONS ARE SHOWN AFTER PLATING

ANGLE: ±1/2°
 CHAMFER: ±5°
 TOLERANCE: .XX ±.01
 .XXX ±.005

3rd ANGLE PROJ.

This drawing is submitted solely for the information and exclusive use of the original addressee. It is not to be divulged in whole or in part, by any firm or individual without written permission from:

FUTEK
 ADVANCED SENSOR TECHNOLOGY, INC.
 10 THOMAS
 IRVINE, CA 92618 USA
 Phone: (949) 465-0900
 Fax: (949) 465-0905

MODEL: QLA122	DWG No.: FO1061
DRAWN BY: H.AU	CHECKED BY: XXXXXX
APPROVED BY: R. WALKER	DATE: AUG. 31, 2004