

Terms and Conditions of Use

This drawing, including all information depicted herein (collectively, "Drawing"), is FUTEK's property and protected under applicable law, including copyright. FUTEK reserves all rights. The Drawing is provided solely for your information and exclusive use. **Except as expressly approved by FUTEK in writing, you may not reproduce or share this Drawing**, in whole or part, with any other firm or individual, or attempt to reverse engineer the Drawing or data contained therein. Any reproduction of this Drawing in whole or part must include this legend.

By accessing the Drawing, you agree that you have read, understand, and agree to abide by the stated Terms and Conditions of Use.

© 2023 FUTEK Advanced Sensor Technology, Inc.

FUTEK MODEL QLA233 CUSTOM DONUT LOAD CELL

STOCK NUMBER: QSH00553

INCH (mm)		R.O.= Rated Output	
WIRING CODE			
+Excitation	-Excitation	+Signal	-Signal
RED	BLACK	GREEN	WHITE

+ OUTPUT
(COMPRESSION)

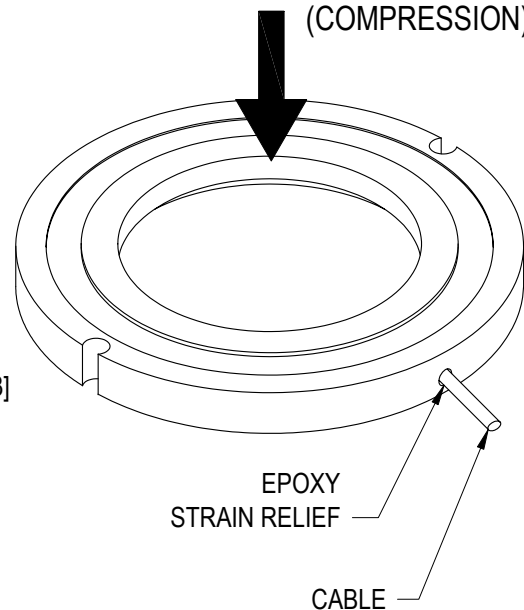
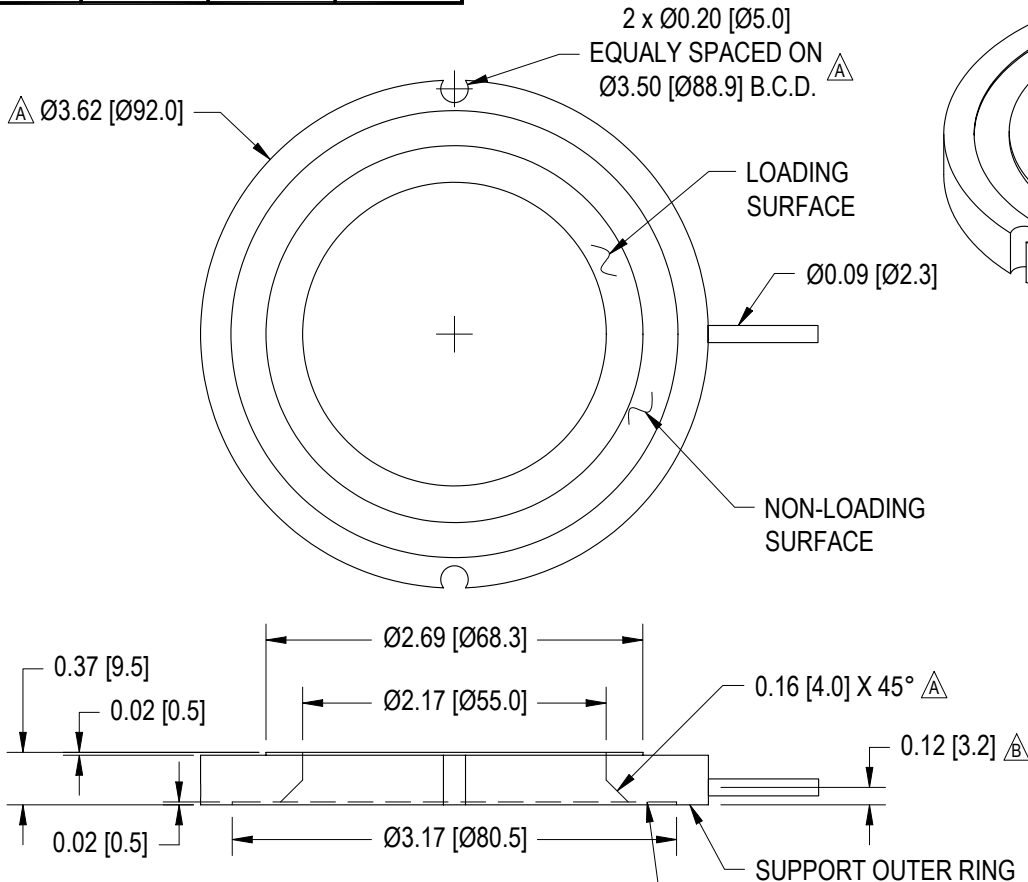

SPECIFICATIONS:

RATED OUTPUT	2.5 mV/V nom.
CAPACITY	20000 lbs
SAFE OVERLOAD	150% of R.O.
ZERO BALANCE	±3% of R.O.
EXCITATION (VDC OR VAC)	18 MAX
BRIDGE RESISTANCE	350/700Ω nom
NONLINEARITY	±2% of R.O.
NONREPEATABILITY	±0.5% of R.O.
TEMP. SHIFT ZERO	±0.02% of R.O./°F
TEMP. SHIFT SPAN	±0.02% of LOAD/°F
COMPENSATED TEMP.	60 to 160°F
OPERATING TEMP.	0 to 200°F
WEIGHT	0.7 lb
MATERIAL	STAINLESS STEEL
CABLE: #29 Awg 4 Conductor Spiral Shielded Teflon Cable, 10 ft Long	

DO NOT APPLY
LOAD ON COVER

NOTE:

WHILE TORQUING BOLTS, HIGH TENSION FORCES WILL OCCUR DURING INSTALLATION, WHICH COULD RESULT IN OVERLOADING THE SENSOR. FUTEK RECOMMENDS CONNECTING SENSOR TO A SYSTEM IN ORDER TO MONITOR THE APPLIED FORCES. FUTEK IS NOT LIABLE OR RESPONSIBLE FOR THE MISHANDLING OF THE SENSOR DURING INSTALLATION.

MATERIAL:

—

HEAT TREATMENT - FINISH:

—

REVISIONS: (Refer to dwg # revision sheet)

$\triangle A$ 03-07-05

$\triangle B$ 04-04-05

OUTLINE DRAWING

STANDARD NOTES: (Unless Otherwise Specified)

- ALL DIMENSIONS ARE IN INCHES
- DRAWING INTERPRETATION DIMS. PER ASME-Y14.5M
- REMOVE BURRS AND BREAK SHARP EDGES .005 - .015
- THREADS PER HANDBOOK H-28
- DIMENSIONS ARE SHOWN AFTER PLATING

ANGLE:

±1/2°

CHAMFER:

±5°

TOLERANCE:

.XX ±.01

.XXX ±.005

3rd ANGLE PROJ.



FUTEK

CAGE: 1X8M6

MODEL: QLA233

DRAWN BY: H. AU

APPROVED BY: XXXXX

This drawing, including all information depicted herein (collectively, "Drawing"), is FUTEK's property and protected under applicable law, including copyright. FUTEK reserves all rights. The Drawing is provided solely for your information and exclusive use. Except as expressly approved by FUTEK in writing, you may not reproduce or share this Drawing, in whole or part, with any other firm or individual, or attempt to reverse engineer the Drawing, or data contained therein. Any reproduction of this Drawing in whole or part must include this legend.

DWG No.: FO1087

CHECKED BY: XXXXX

DATE: MAR. 4, 2005