

FUTEK MODEL QLA298

Custom Donut Load Cell

STOCK NUMBER: QSH01130

| | | | |
|--------------------|-------------|--------------------|---------|
| INCH (mm) | | R.O.= Rated Output | |
| WIRING CODE | | | |
| +Excitation | -Excitation | +Signal | -Signal |
| RED | BLACK | GREEN | WHITE |
| Shield | | | |
| Floating | | | |

+OUTPUT
(COMPRESSION)

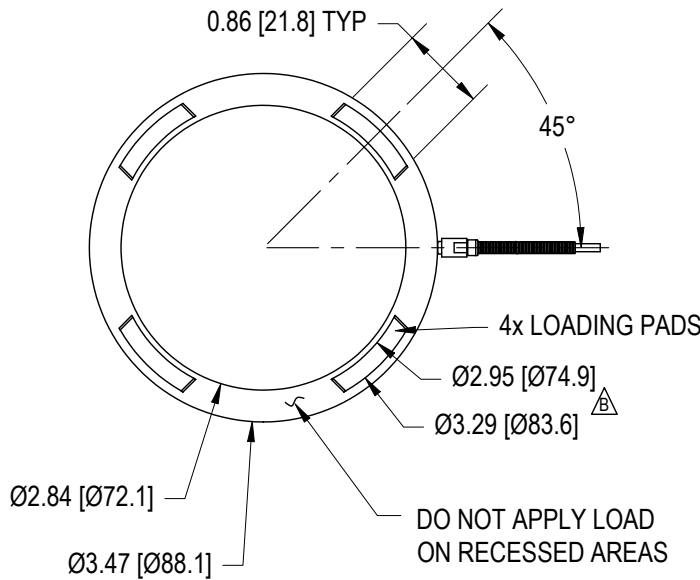
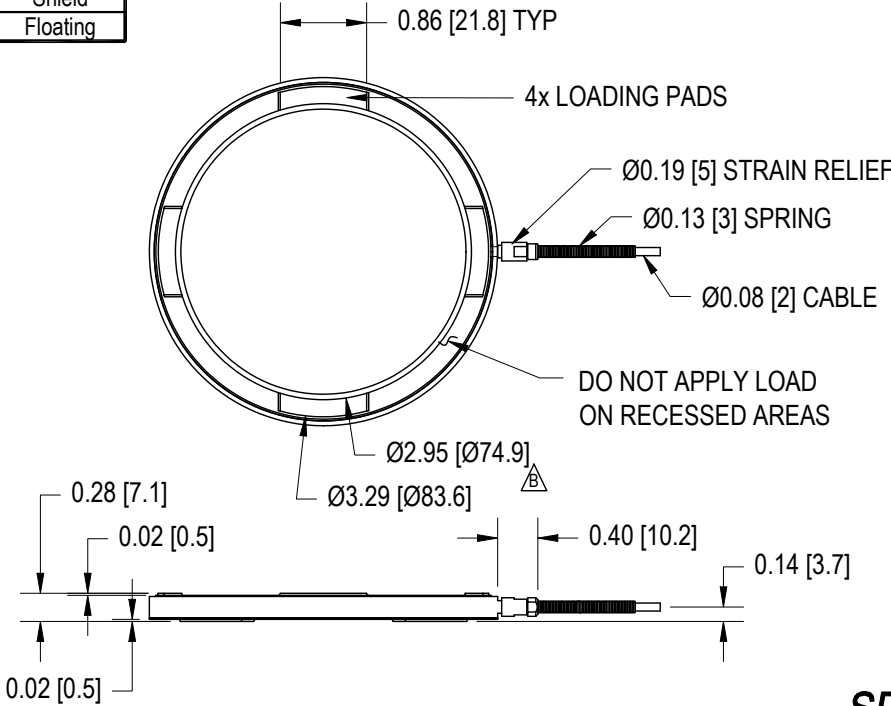
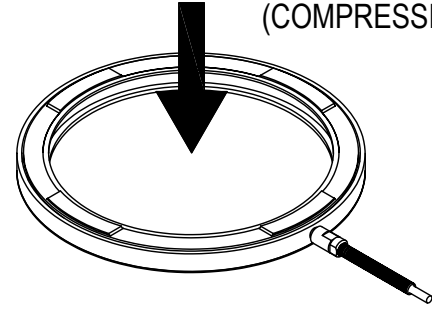

SPECIFICATIONS:

| | |
|--|---------------------------------------|
| RATED OUTPUT | 1.5 mV/V nom. |
| CAPACITY | 10000 N (2250 lb) |
| SAFE OVERLOAD | 350% of R.O. |
| ZERO BALANCE | ±3% of R.O. |
| EXCITATION (VDC OR VAC) | 15 MAX |
| BRIDGE RESISTANCE | 350 Ω nom |
| NONLINEARITY | ±3% of R.O. |
| NONREPEATABILITY | ±0.25% of R.O. |
| TEMP. SHIFT ZERO | ±0.02% of R.O./°F (0.038% of R.O./°C) |
| TEMP. SHIFT SPAN | ±0.02% of LOAD/°F (0.038% of LOAD/°C) |
| COMPENSATED TEMP. | 59 to 104°F (15 to 40°C) |
| OPERATING TEMP. | -40 to 200°F (-40 to 93°C) |
| WEIGHT | approx 3 oz |
| MATERIAL | 17-4ph S.S. |
| CABLE: 29 AWG, 4 Conductor Spiral Shielded Silicone Cable, 6 ft [2m] Long | |

NOTES:

- 1) MOUNTING SURFACES THAT CONTACT LOADING PADS ARE TO MAINTAIN 0.0005 FLATNESS OR BETTER TO OBTAIN OPTIMAL ACCURACY.

MATERIAL:

—

HEAT TREATMENT - FINISH:

—

REVISIONS: (Refer to dwg # revision sheet)

△ 7-11-08

△ 7-23-08

OUTLINE DRAWING

STANDARD NOTES: (Unless Otherwise Specified)

- ALL DIMENSIONS ARE IN INCHES
- DRAWING INTERPRETATION DIMS. PER ASME-Y14.5M
- REMOVE BURRS AND BREAK SHARP EDGES .005 - .015
- THREADS PER HANDBOOK H-28
- DIMENSIONS ARE SHOWN AFTER PLATING

ANGLE:
±1/2°

CHAMFER:
±5°

TOLERANCE:
.X ±0.1
.XX ±0.01
.XXX ±0.005

3rd ANGLE PROJ.



This drawing is submitted solely for the information and exclusive use of the original addressee. It is not to be divulged in whole or in part, by any firm or individual without written permission from:

FUTEK
ADVANCED SENSOR TECHNOLOGY, INC.

10 THOMAS
IRVINE, CA 92618 USA
Phone: (949) 465-0900
Fax: (949) 465-0905

CAGE: 1X8M6

MODEL: **QLA298**

DWG No.: **F01217-B**

DRAWN BY: **R. WALKER**

CHECKED BY: **J.V. MEISELBACH**

APPROVED BY: —

DATE: **June 23, 2008**