

## Terms and Conditions of Use

This drawing, including all information depicted herein (collectively, "Drawing"), is FUTEK's property and protected under applicable law, including copyright. FUTEK reserves all rights. The Drawing is provided solely for your information and exclusive use. **Except as expressly approved by FUTEK in writing, you may not reproduce or share this Drawing**, in whole or part, with any other firm or individual, or attempt to reverse engineer the Drawing or data contained therein. Any reproduction of this Drawing in whole or part must include this legend.

By accessing the Drawing, you agree that you have read, understand, and agree to abide by the stated Terms and Conditions of Use.

© 2023 FUTEK Advanced Sensor Technology, Inc.

# FUTEK MODEL QLA413

## Custom 54mm ID Thru Hole Load Cell

ITEM NUMBER: QSH02027

DESIGNED TO MINIMIZE THE EFFECTS OF SHEAR (Fx and Fy) AND MOMENT (Mx and My) LOADS

INCH [mm] | R.O. = Rated Output

WIRING CODE (WC1)			
+ Excitation	- Excitation	+ Signal	- Signal
RED	BLACK	GREEN	WHITE
Shield			
FLOATING			

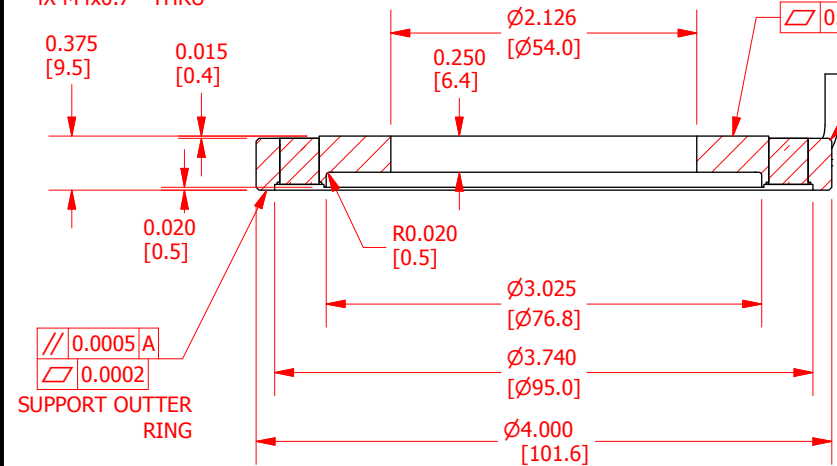
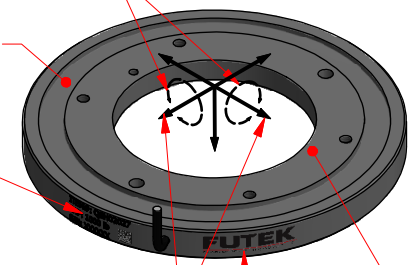
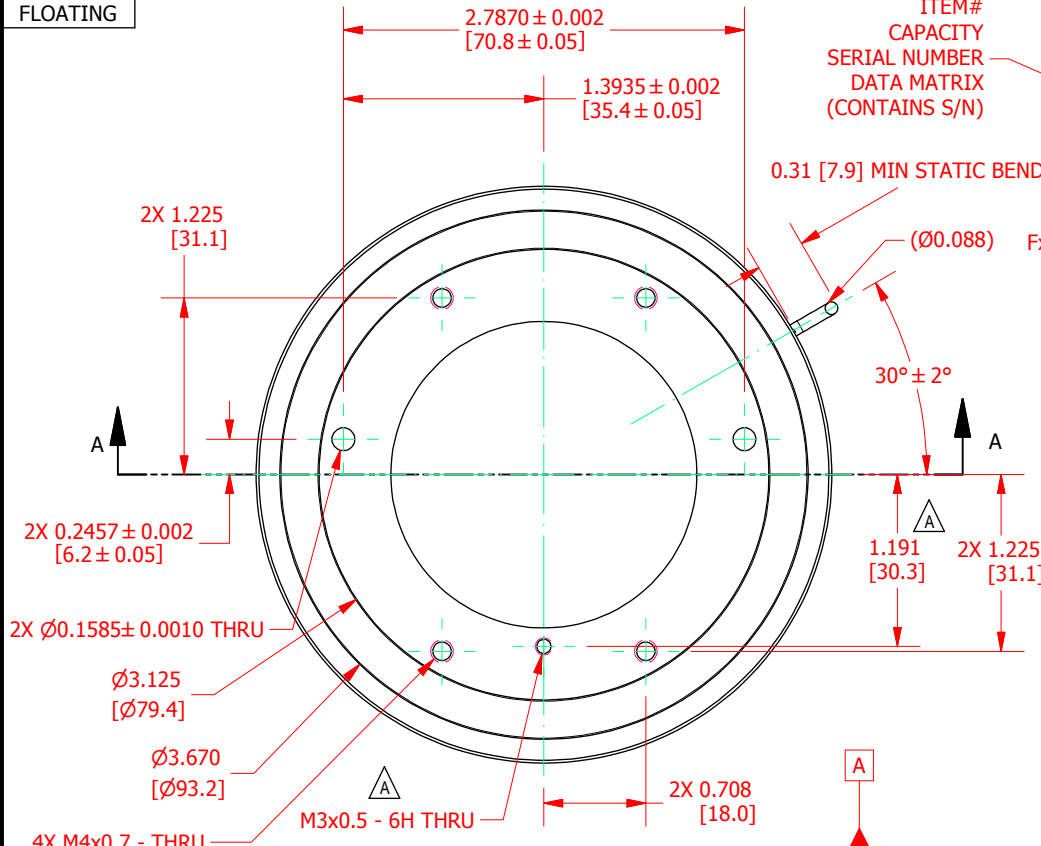

**SPECIFICATIONS:**

RATED OUTPUT	3 mV/V nom.
CAPACITY	100 lb. [4440N]
SAFE OVERLOAD	150 % of R.O.
ZERO BALANCE	±5% of R.O.
EXCITATION (VDC OR VAC)	15 MAX
BRIDGE RESISTANCE	700 Ω nom.
NONLINEARITY	±1% of R.O.
HYSTERESIS	±1% of R.O.
NONREPEATABILITY	±0.5% of R.O.
TEMP. SHIFT ZERO	±0.01% of R.O./°F (±0.018 of R.O./°C)
TEMP. SHIFT SPAN	±0.02% of LOAD/°F (±0.036 of LOAD/°C)
COMPENSATED TEMP.	50 to 100 °F (10 to 38 °C)
OPERATING TEMP	-60 to 200 °F (-51 to 93 °C)
WEIGHT (approx)	0.75 lb [340.1 g]
MATERIAL	17-4 PH S.S.
DEFLECTION	0.003 [0.013] nom.
CABLE: #29 Awg 4 Conductor Spiral Shielded Silicone Cable, 10 ft [3.0 m] Long	
MAX Fx/Fy RESISTANCE	100 lb
MAX Mx/My RESISTANCE	400 in-lb

CUSTOMER APPROVAL- COMPANY:

CUSTOMER APPROVAL- NAME / DATE:

REVISIONS: (Refer to dwg # revision sheet)

A	8/17/2018
---	-----------

## OUTLINE DRAWING

STANDARD NOTES: (Unless Otherwise Specified)

ALL DIMENSIONS ARE IN INCHES

DRAWING INTERPRETATION DIMS. PER ASME-Y14.5M

REMOVE BURRS AND BREAK SHARP EDGES .005 - .015

THREADS PER HANDBOOK H-28

DIMENSIONS ARE SHOWN AFTER PLATING

3rd ANGLE PROJ.

ANGLE: ± 1/2°

CHAMFER: ± 5°

TOLERANCE:  
 .X ± 0.1"  
 .XX ± 0.01"  
 .XXX ± 0.005"

**FUTEK**

This drawing, including all information depicted herein (collectively, "Drawing"), is FUTEK's property and protected under applicable law, including copyright. FUTEK reserves all rights. The Drawing is provided solely for your information and exclusive use. Except as expressly approved by FUTEK in writing, you may not reproduce or share this Drawing, in whole or part, with any other firm or individual, or attempt to reverse engineer the Drawing or data contained therein. Any reproduction of this Drawing in whole or part must include this legend.

MODEL: <b>QLA413</b>	DWG No.: <b>FO1473-A</b>
DRAWN BY: S. MICHEL	CREATED DATE: 8/16/2018
APPROVED BY: R. WALKER	APPROVED DATE: 8/16/2018
CHECKED BY:	CAGE: 1X8M6 SHEET: 1 OF 1