

## Terms and Conditions of Use

This drawing, including all information depicted herein (collectively, "Drawing"), is FUTEK's property and protected under applicable law, including copyright. FUTEK reserves all rights. The Drawing is provided solely for your information and exclusive use. **Except as expressly approved by FUTEK in writing, you may not reproduce or share this Drawing**, in whole or part, with any other firm or individual, or attempt to reverse engineer the Drawing or data contained therein. Any reproduction of this Drawing in whole or part must include this legend.

By accessing the Drawing, you agree that you have read, understand, and agree to abide by the stated Terms and Conditions of Use.

© 2023 FUTEK Advanced Sensor Technology, Inc.

# FUTEK MODEL QMA135

## Custom Triaxial Multicomponent Load and Torque Sensor

ITEM NUMBER: QSH01644

INCH [mm] | R.O.= Rated Output

A B C

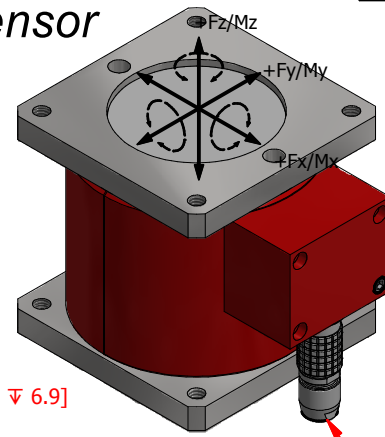

+F (Tension) = +Output  
Moment (CW) = +Output

LEMO MATING CONNECTOR NOT INCLUDED

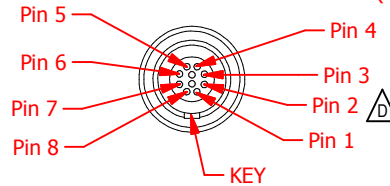
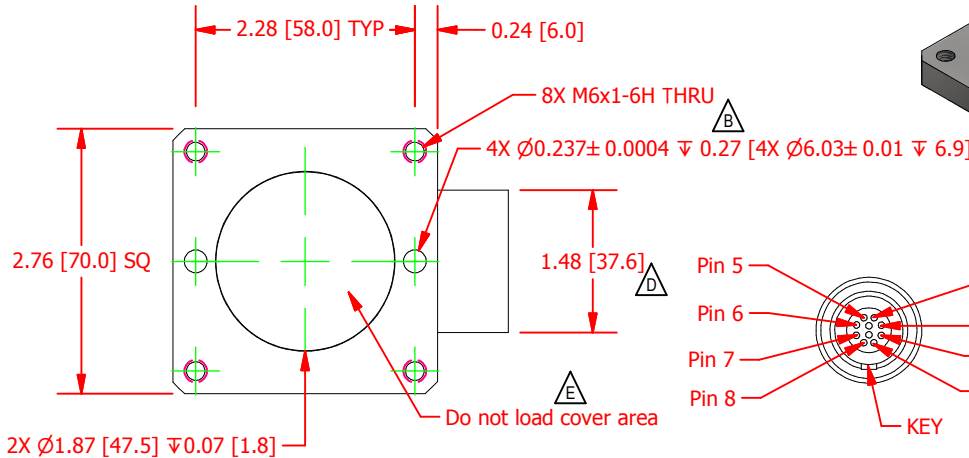

Pin #	Code	Channel
1	+E	Fy, Fz, Mz
2	-E	Fy, Fz, Mz
3	+S	Fy
4	-S	Fy
5	+S	Fz
6	-S	Fz
7	+S	Mz
8	-S	Mz

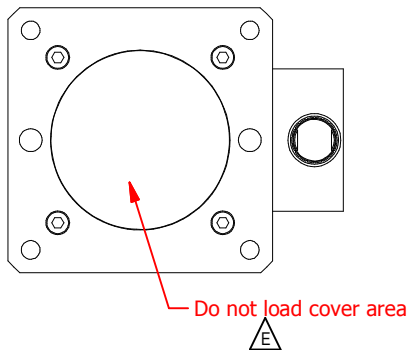
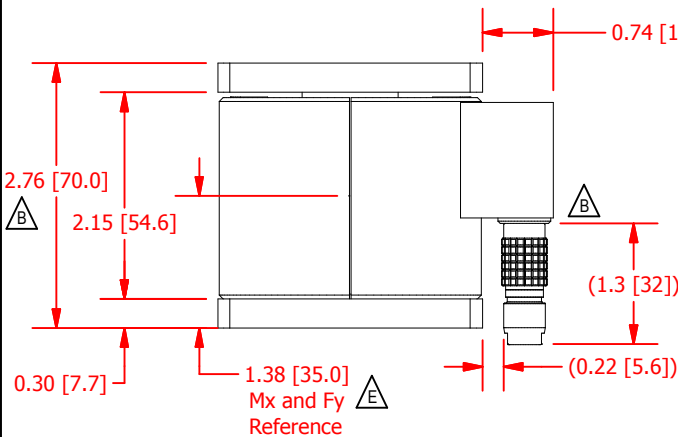

### SPECIFICATIONS:

RATED OUTPUT	Fy, Fz 1 mV/V, Mz 2 mV/V
CAPACITY	Fy: 1200 N, Fz: 300 N, Mz: 50 Nm
SAFE OVERLOAD	150% of R.O.
MOMENT LOAD	Mx: 150 Nm (nonmeasurement)
ZERO BALANCE	±3% of R.O.
EXCITATION (VDC OR VAC)	18 MAX
OUTPUT BRIDGE RESISTANCE	350/700 Ω nom
NONLINEARITY	±1% of R.O.
HYSTERESIS	±1% of R.O.
NONREPEATABILITY	±0.25% of R.O.
STIFFNESS*	Fy: 47,000 N/mm, Fz: 39,000 N/mm, Mz: 19,000 Nm/rad
TEMP. SHIFT ZERO	±0.02% of R.O./°F (±0.036 of R.O./°C)
TEMP. SHIFT SPAN	±0.02% of LOAD/°F (±0.036 of LOAD/°C)
COMPENSATED TEMP.	60 to 160 °F (16 to 71 °C)
OPERATING TEMP.	-40 to 180 °F (-40 to 82 °C)
MATERIAL	17-7ph S.S. Flexure, Red Anodized Aluminum (Cover)
CONNECTOR: 10 PIN LEMO RECEPTACLE, EGG. 1B.310.CLL	

\* Values derived from simulation analysis (FEA)

CUSTOMER APPROVAL- COMPANY:

CUSTOMER APPROVAL- NAME / DATE:

REVISIONS: (Refer to dwg # revision sheet)

REV	DATE
A	05/20/2013
B	5/24/2013
C	5/31/2013
D	6/20/2013
E	10/03/2013

## OUTLINE DRAWING

STANDARD NOTES: (Unless Otherwise Specified)

ALL DIMENSIONS ARE IN INCHES  
DRAWING INTERPRETATION DIMS. PER ASME-Y14.5M  
REMOVE BURRS AND BREAK SHARP EDGES .005 - .015  
THREADS PER HANDBOOK H-28  
DIMENSIONS ARE SHOWN AFTER PLATING

ANGLE:  
± 1/2°

CHAMFER:  
± 5°

TOLERANCE:  
.X ± 0.1"  
.XX ± 0.01"  
.XXX ± 0.005"

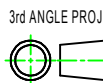

# FUTEK

This drawing, including all information depicted herein (collectively, "Drawing"), is FUTEK's property and protected under applicable law, including copyright. FUTEK reserves all rights. The Drawing is provided solely for your information and exclusive use. Except as expressly approved by FUTEK in writing, you may not reproduce or share this Drawing, in whole or part, with any other firm or individual, or attempt to reverse engineer the Drawing or data contained therein. Any reproduction of this Drawing in whole or part must include this legend.

MODEL: <b>QMA135</b>	DWG No.: <b>FO1347-E</b>
DRAWN BY: R. Walker	CREATED DATE: 4/30/2013
APPROVED BY: _____	APPROVED DATE: _____
CHECKED BY: E. Pano	CAGE: 1X8M6 SHEET: 1 OF 1