

At the heart of many automated assembly platforms and robots is an electric motor. If the motor is the heart, then that means the brain is the controller and closed loop control system.

However, the motor and controller wouldn't be complete without sensors to provide relevant control information and complete the control loop. So, to extend the analogy, these sensors would be the nerves. One of these nerves would be a torque sensor, but just like an organ transplant, you cannot add any torque sensor to your system; the torque sensor needs to have the necessary specifications to meet your system's needs. To preliminarily determine your sensor's specifications, you will need to:

1. Determine the maximum torque to be measured
2. Determine the necessary system accuracy
3. Determine Electrical Interface Requirements

### Step 1: Determine the Maximum Motor Torque

When selecting a torque sensor, you must determine the maximum torque you expect the motor and/ or gearhead to produce. A common misconception is that the nominal or maximum continuous torque determines the maximum capacity, when in reality the nominal or maximum continuous torque does not take into consideration the potential for a motor to stall. Since stall torque can be several orders of magnitude greater than nominal or continuous torque, you would

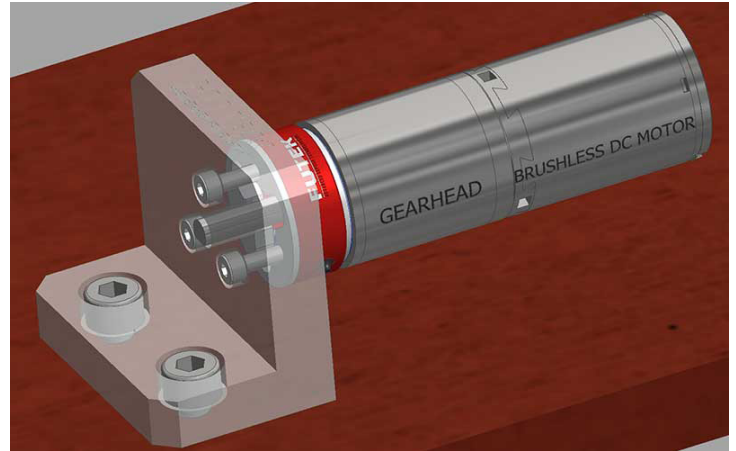

Figure 1: FUTEK's QTA141 Micro Reaction Torque Sensor directly mounted to a brushless DC motor and gearhead.

damage or destroy the sensor in a stall scenario if you chose the nominal maximum torque. Therefore, it is important that you size your torque sensor based on the expected stall torque to prevent damaging the sensor.

### Step 2: Determine the Necessary System Accuracy

The accuracy of your torque sensor can be defined by the smallest amount of torque the sensor can reliably measure. If the minimum generated torque has not yet been determined for your system, then you can preliminarily determine your minimum torque using the torque gradient and minimum operating speed of the motor. For example, a servo motor that has a torque gradient of 0.017 mNm/RPM at 1000 RPM will have a minimum operating torque of 0.017 Nm. This value would represent the system accuracy that would be necessary for selecting the proper torque sensor.

Drawing Number: ED1094

#### Sensor Solution Source

Load · Torque · Pressure · Multi-Axis · Calibration · Instruments · Software

[www.futek.com](http://www.futek.com)



U.S. Manufacturer

## Torque Sensor Sizing Criteria for Servo Motors

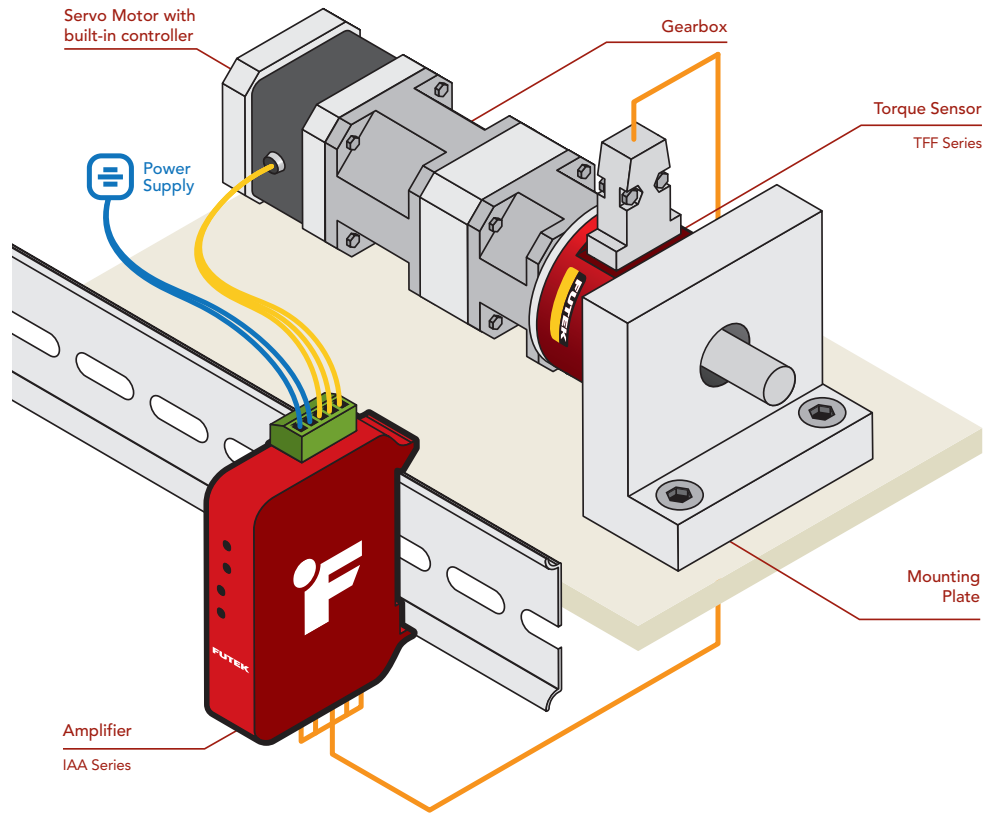

Figure 2: An example of the relationship between a torque sensor, amplifier, and a PLC/Motor Controller.

With the minimum and maximum operating torque values, the last thing you will need to determine are the electrical interface requirements for your system.

### Step 3: Determine Electrical Interface Requirements

Your DAQ or PLC has specific signal inputs it can accept and your sensor solution must be able to output those signals. For instance, some systems can handle +/- 10 VDC or 4-20 mA, while other systems can handle mV/V or SPI signals. Knowing what your system supports will allow you to select a sensor that can interface with your system. However, if your sensor cannot produce the analog signals your DAQ or PLC supports, you will need an amplifier to bridge the gap.

The amplifier, used for full bridge sensors with mV/V signal output, will convert a mV/V signal to voltage, current, or the correct signal for your DAQ or PLC. With the requirements of your DAQ and PLC in mind, you'll be able to select the sensor and any supporting hardware you need for your system.

Now you are ready to explore torque sensor options and pick the perfect one for your application. Keeping your torque maximum, minimums, and electrical requirements in mind, you'll be able to narrow down your selection of sensors and work with manufacturers to find the sensor that fits your needs perfectly.